

# 108 STRIKE INSTALLATION

## 1 PREPARE AND INSTALL SCREWS THROUGH 2 STRIKE SLOTS.

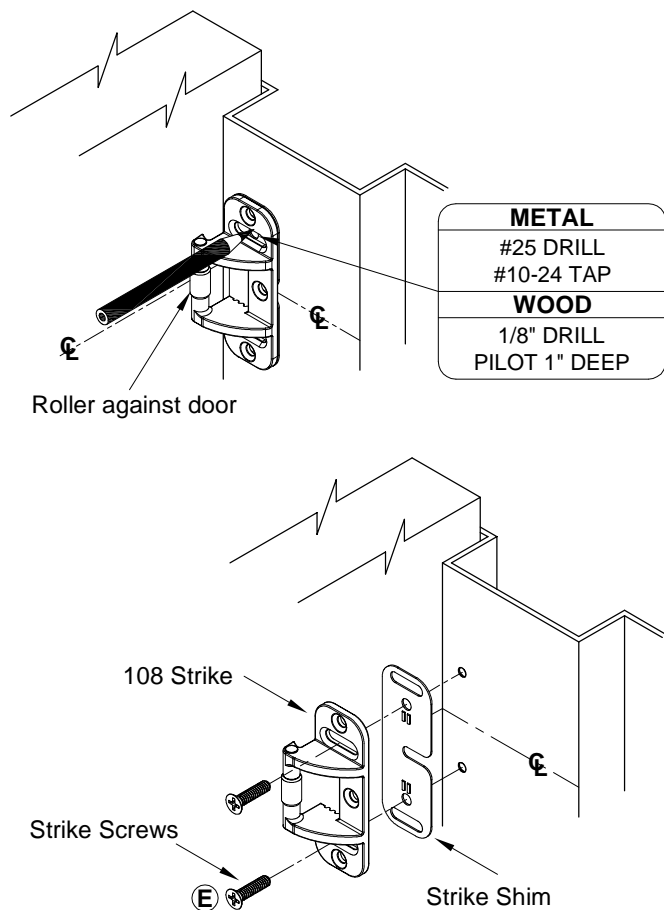

## 2 INSTALL STRIKE HOOK AND ADDITIONAL STRIKE SCREWS.

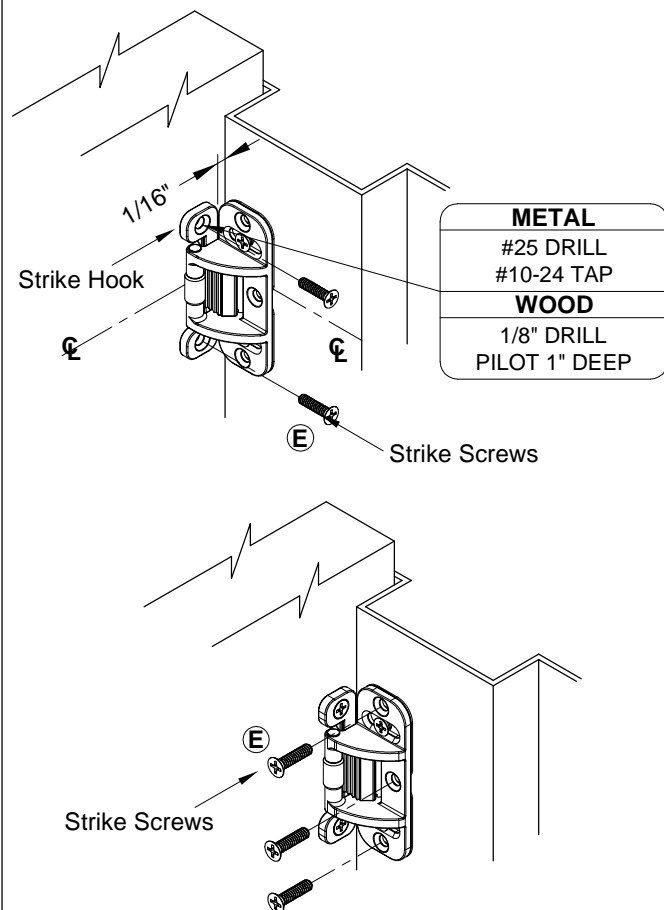

## 3 TEMPLATE ALIGNS AS SHOWN.

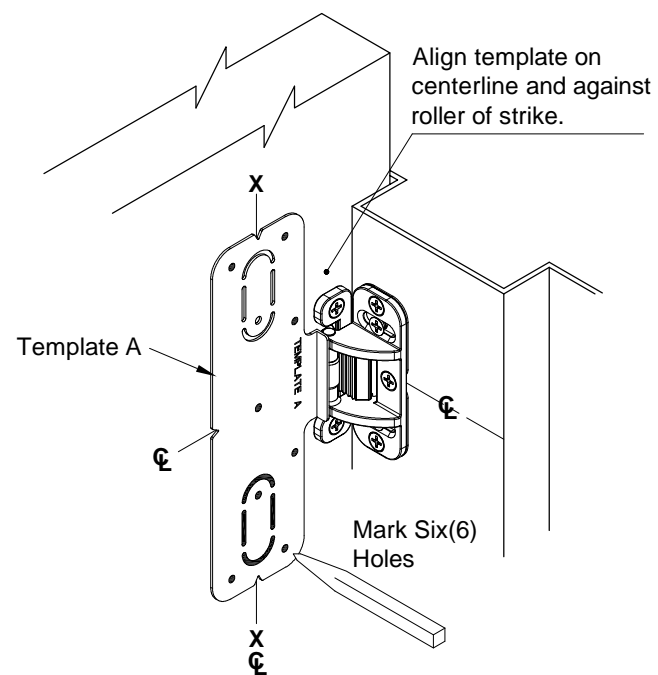

# LSDA PD9200R / PDF9200R SERIES RIM EXIT DEVICE

## INSTALLATION INSTRUCTIONS

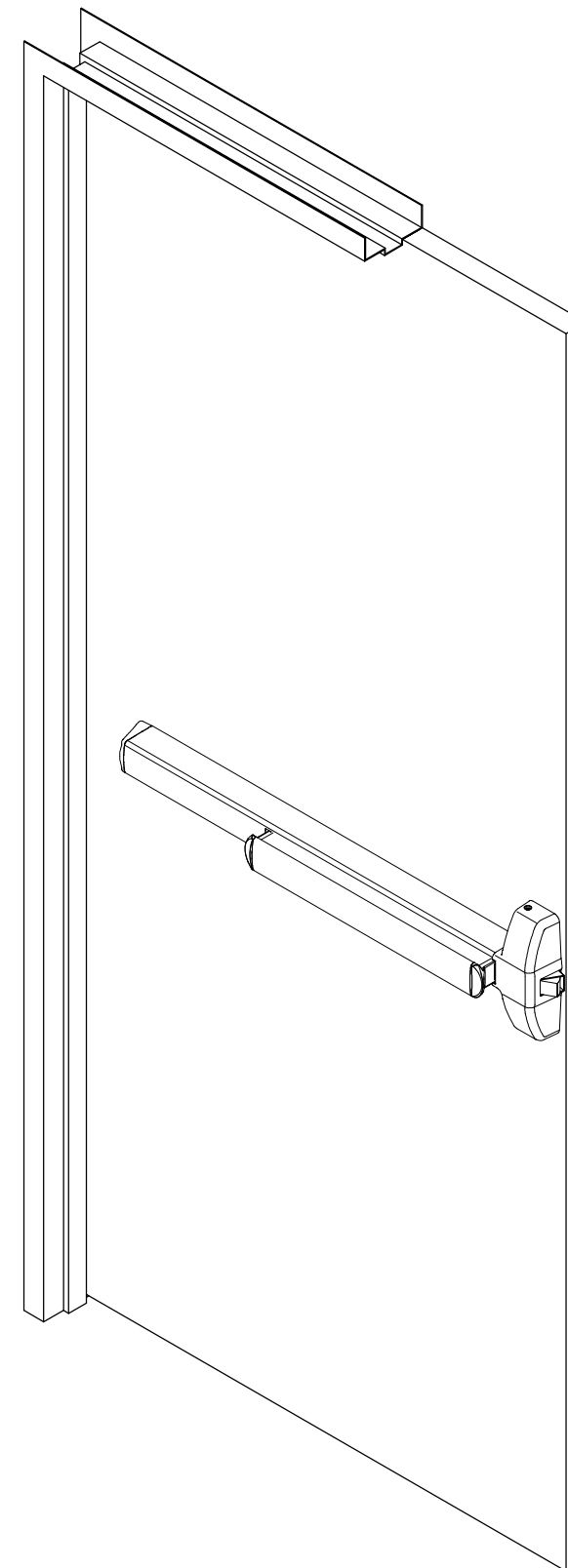

# SECURITY INDICATOR KIT INSTALLATION

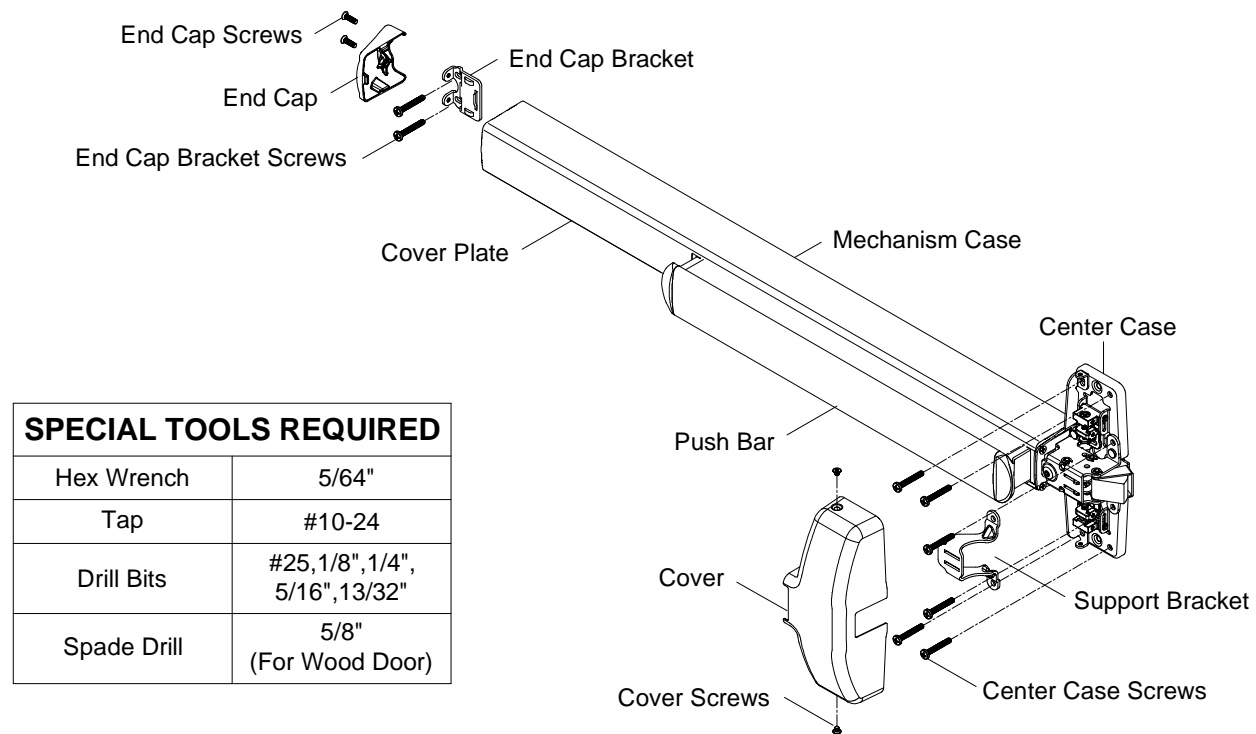

## SPECIAL TOOLS REQUIRED

|             |                                |
|-------------|--------------------------------|
| Hex Wrench  | 5/64"                          |
| Tap         | #10-24                         |
| Drill Bits  | #25, 1/8", 1/4", 5/16", 13/32" |
| Spade Drill | 5/8"<br>(For Wood Door)        |

## SCREW CHART

| LOCATION               | METAL                                    | SEX BOLTS   | WOOD                                     |
|------------------------|--|---|--|
| Center Case Screws     | <b>C</b><br>No.10-24 x 1-11/32"<br>6 PCS | <b>C</b><br>No.10-24 x 1-11/32"<br>6 PCS<br><b>G</b><br>No.10-24 x 1-3/32"<br>6 PCS | <b>A</b><br>No.10-12 x 1-11/32"<br>6 PCS |
| End Cap Bracket Screws | <b>C</b><br>No.10-24 x 1-11/32"<br>2 PCS | <b>C</b><br>No.10-24 x 1-11/32"<br>2 PCS<br><b>G</b><br>No.10-24 x 1-3/32"<br>2 PCS | <b>A</b><br>No.10-12 x 1-11/32"<br>2 PCS |
| 106 Strike Screws      | <b>E</b><br>No.10-24 x 11/16"<br>3 PCS   |   | <b>B</b><br>No.10-12 x 1-11/32"<br>3 PCS |
| 108 Strike Screws      | <b>E</b><br>No.10-24 x 11/16"<br>7 PCS   |   | <b>B</b><br>No.10-12 x 1-11/32"<br>7 PCS |
| End Cap Screws         | <b>J</b>                                 | No.8-32 x 5/8"<br>2 PCS   |  |
| Cover Screws           | <b>I</b>                                 | No.8-32 x 5/32"<br>2 PCS  |  |
| Cylinder Screws        | <b>C</b>                                 | No.10-24 x 1-11/32"<br>2 PCS  |  |

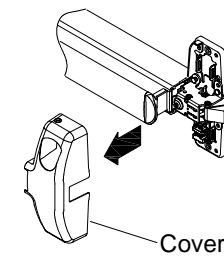

1. Remove cover.

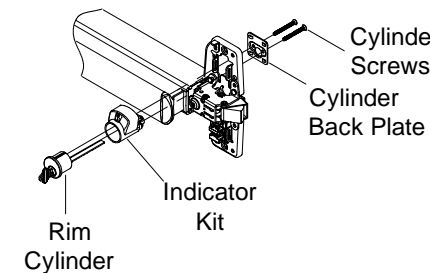

2. Mount rim cylinder to Indicator Kit and attach assembly to center case with two(2) cylinder screws through cylinder back plate as shown.

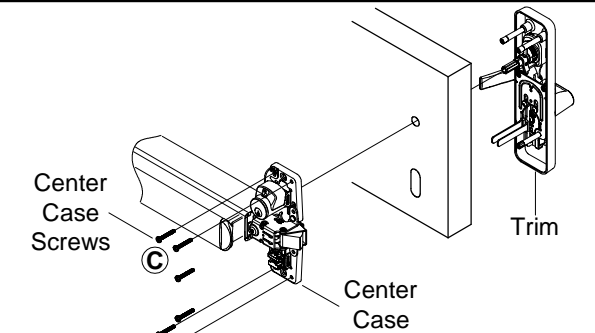

3. Install center case and trim with center case screws. **NOTE:** See "Trim Instructions" to install trim cylinder.

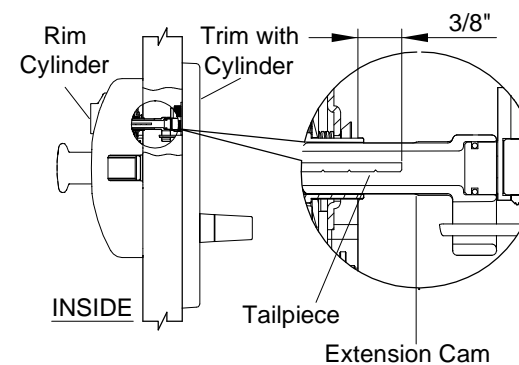

4. for door ranges from 1-3/4" to 2-1/4" thick, the distance between the tailpiece's endpoint after cropping and the base of the center case should be of 3/8".

**CAUTION!**  
If tailpiece is too far into cylinder cam, it may interfere with both cylinders' operation.

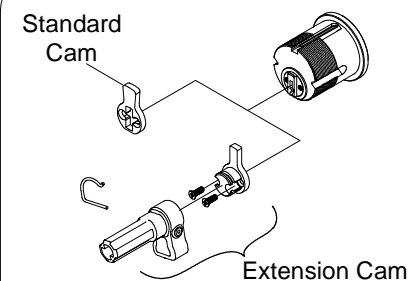

Remove standard cam and replace with extension cam.

## CUT DEVICE (IF REQUIRED)

Recommended minimum clearance between frame and device end (with end cap removed) is 1-1/2".

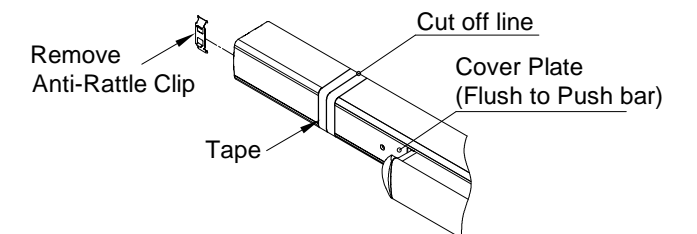
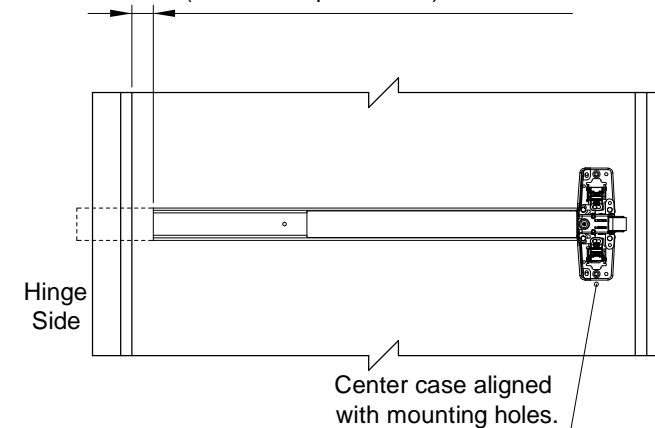

1. With anti-rattle clip removed, tape and mark area being cut.

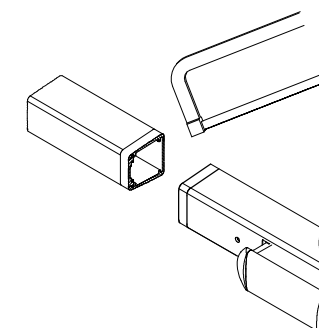

2. Cut off device and deburr. **NOTE:** Device must be cut square for proper end cap fit.

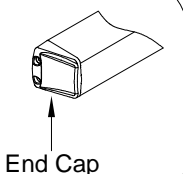

## 9 ADJUST AND SECURE STRIKE.

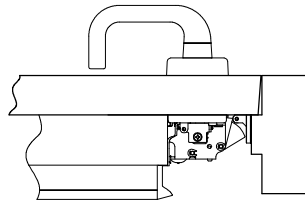

Fasten strike to frame and adjust strike so that the device latches tightly without binding, apply third center screw once adjustment is complete.

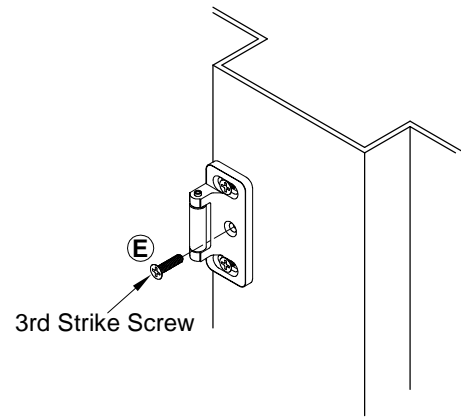

3rd Strike Screw

## 10 INSTALL COVER.

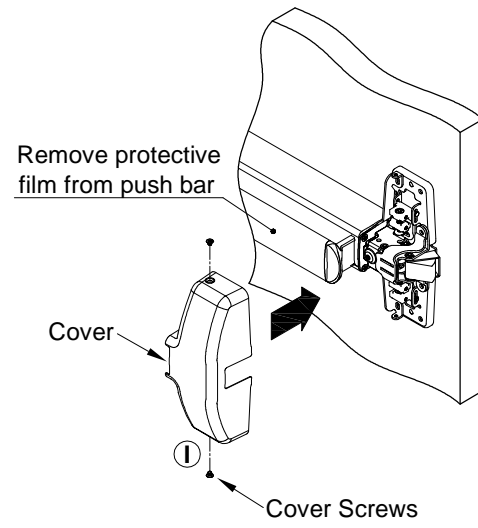

Remove protective film from push bar

Cover

Cover Screws

Attach cover to center case with two(2) center case screws.

## OPTIONAL DOGGING

### CYLINDER DOGGING

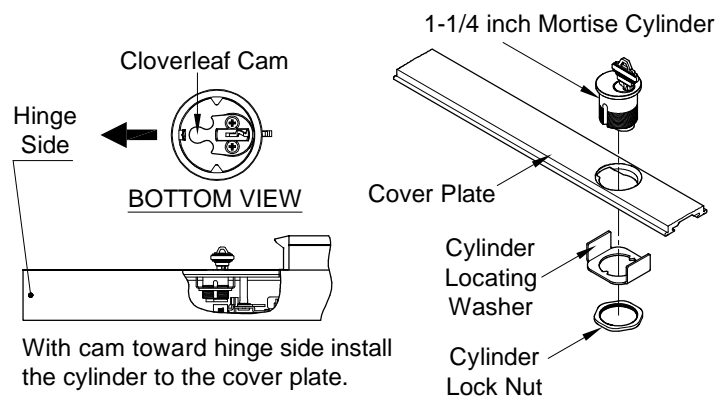

With cam toward hinge side install the cylinder to the cover plate.

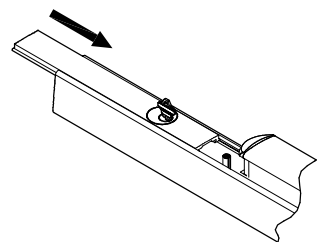

Slide cover plate in position in the mechanism case.

### DOGGING CHECK

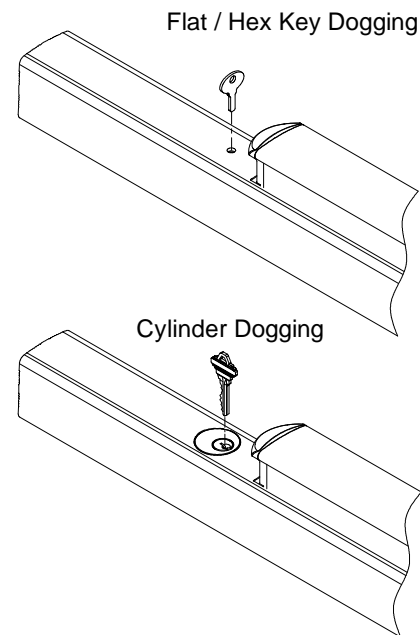

Depress push bar and turn flat / hex wrench or key one full turn for dogging check.

## DOOR PREPARATION CHART

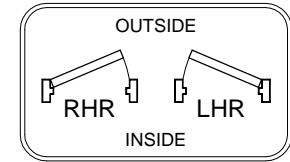

### END CAP BRKT. - 2 HOLES

| SURFACE MOUNT               | SEX BOLTS  |
|-----------------------------|--|
| <b>METAL</b>                | <b>METAL</b>   |
| #25 DRILL<br>#10-24 TAP     | 1/4" DRILL (DEVICE SIDE)<br>13/32" DRILL (TRIM SIDE) |
| <b>WOOD</b>                 | <b>WOOD</b>  |
| 1/8" DRILL<br>PILOT 1" DEEP | 13/32" DRILL THRU                                    |

### CENTER CASE - 4 HOLES

| SURFACE MOUNT               | SEX BOLTS OR TRIM                                    |
|-----------------------------|--|
| <b>METAL</b>                | <b>METAL</b>   |
| #25 DRILL<br>#10-24 TAP     | 1/4" DRILL (DEVICE SIDE)<br>13/32" DRILL (TRIM SIDE) |
| <b>WOOD</b>                 | <b>WOOD</b>  |
| 1/8" DRILL<br>PILOT 1" DEEP | 13/32" DRILL THRU                                    |

\*PREPARE HOLES AFTER LOCK SIDE OF DEVICE IS MOUNTED AND HINGE SIDE OF DEVICE IS LEVELED

RHR shown (LHR opposite)

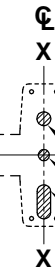

### CENTER CASE - 2 SUPPORT HOLES

| SURFACE MOUNT               |
|-----------------------------|
| <b>METAL</b>                |
| #25 DRILL<br>#10-24 TAP     |
| <b>WOOD</b>                 |
| 1/8" DRILL<br>PILOT 1" DEEP |

### DOOR CUT-OUTS

FOR TRIM APPLICATIONS WITH WORKING LEVER, THUMBPIECE, OR KNOB: MARK WITH TEMPLATE AND CUT OUT: (CUT DEVICE SIDE ONLY)

OUTSIDE CYLINDER APPLICATIONS: MARK WITH TEMPLATE AND CUT OUT:  
**METAL DOOR (CUT DEVICE SIDE)**  
**WOOD DOOR (CUT THRU)**  
(5/8" DIA.)

DOUBLE CYLINDER APPLICATIONS: MARK WITH TEMPLATE AND CUT OUT:  
**METAL DOOR (CUT DEVICE SIDE)**  
**WOOD DOOR (CUT THRU)**  
(7/8" DIA.)

# 1 DRAW HORIZONTAL DEVICE AND STRIKE CENTERLINE.

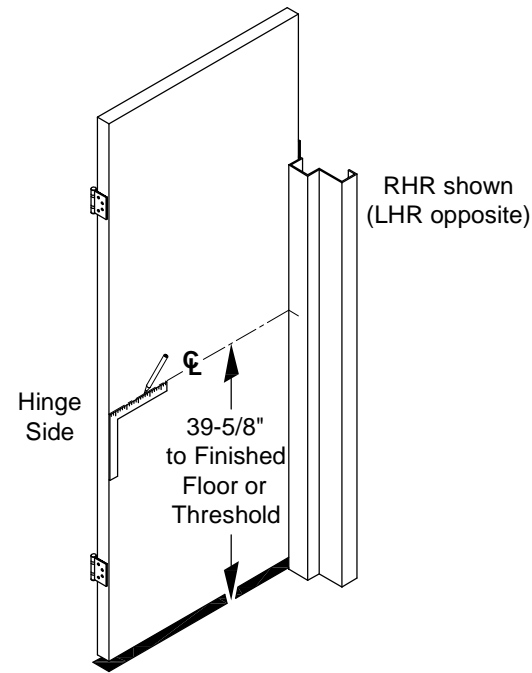

Close door, mark horizontal centerline on inside face of door and on lock side door stop 39-5/8" from finished floor as shown (continue horizontal centerline to outside face of door if trim is used).

# 2 ALIGN STRIKE ON HORIZONTAL CENTERLINE (☉) AND MARK TWO(2) SLOTTED HOLES.

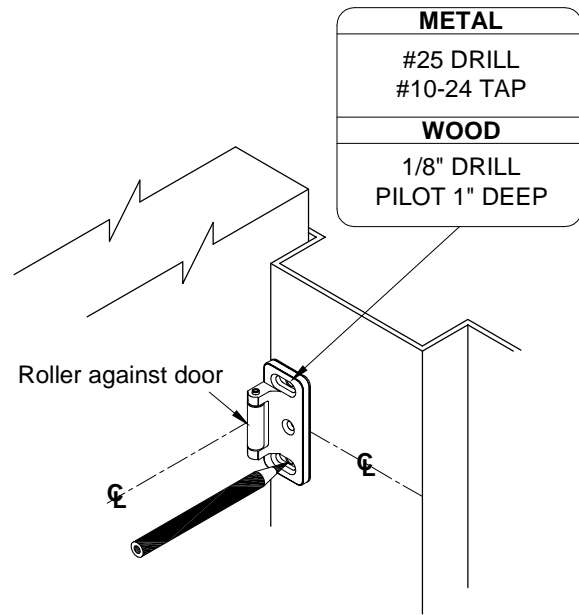

Use strike as template and place on door stop and against inside face of door, so the horizontal centerline on strike lines up with the horizontal centerline on door stop and door. Mark centers and drill / tap holes as required.

# 3 INSTALL STRIKE AND SHIM.

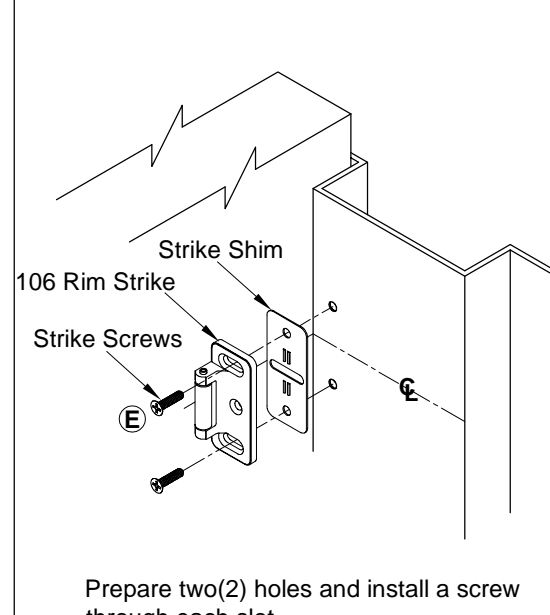

Prepare two(2) holes and install a screw through each slot.

For 108 strike see back cover of this instruction.

# 4 POSITION TEMPLATE AGAINST STRIKE AND ON ☉ AND MARK DOOR.

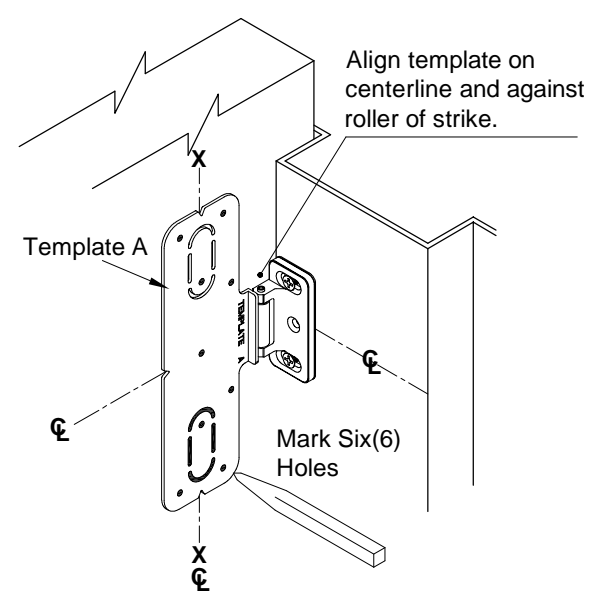

Tape "TEMPLATE A" (and trim template if trim is using) to the door so that the centerlines on the template line up with centerlines on the door. Mark centers and drill/tap the required holes as indicated on the template.

# 5 PREPARE DOOR FOR DEVICE AND TRIM.

See trim instructions for outside door preparation. Locate same vertical centerline for both sides. Use extra care if edge of door is beveled. Be sure X-X vertical centerline is parallel to edge of door.

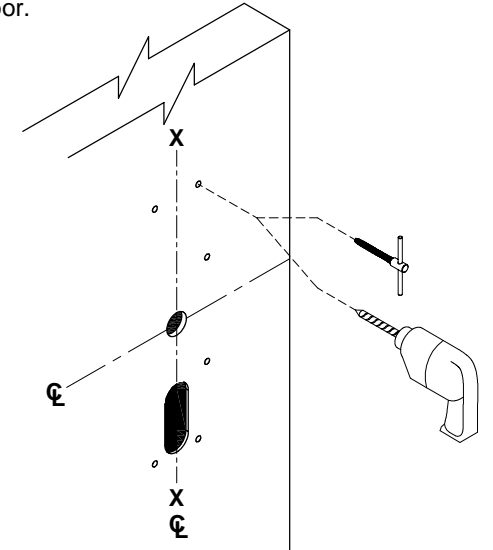

See "DOOR PREPARATION CHART" on page 3 for drill, tap and cut-out information.

# 6 DETERMINE USE OF NL DRIVE SCREW.

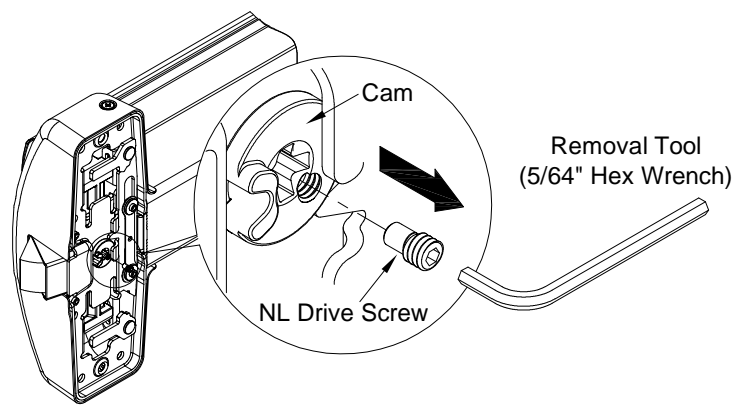

NL driver screw is factory assembled in cam on back of device center case, when the NL drive screw is left in back of center case, the outside cylinder will function only as a Night Latch.

- NOTE:**
1. **DO NOT** remove NL drive screw for Pull Plate or Escutcheon with night latch cylinder.
  2. **REMOVE** NL drive screw from back of center case when installing trim that has a functional lever, knob, or thumbpiece AND an outside cylinder to lock and unlock the trim.

# 7 INSTALL TRIM (IF USING) AND SECURE DEVICE CENTER CASE TO DOOR.

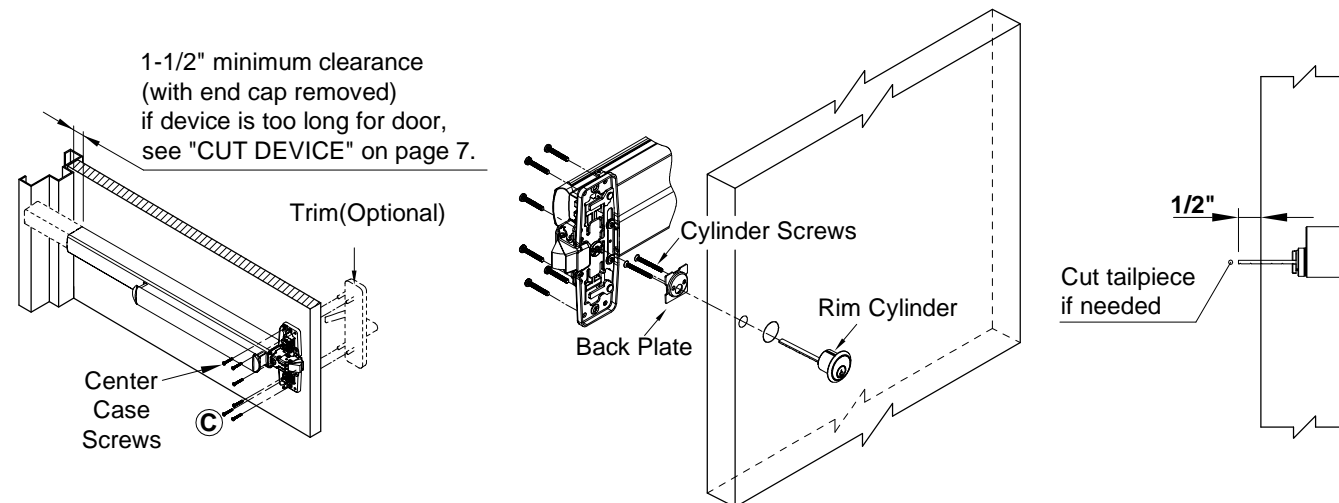

1. **DEVICE WITH TRIM** - See "Trim Instructions".
2. **CYLINDER ONLY** - Install cylinder with cylinder back plate as shown. Make sure the tailpiece is extending 1/2" from the inside face of door. Insert tailpiece into cam in the center case and mount it to the door with six(6) center case screws.
3. **EXIT ONLY** - Mount center case to the door with six(6) center case screws.

**For FIRE EXIT DEVICES:**

Two(2) sex bolts and support screws are required for composite (wood, plastic and steel covered), wood core, sheet metal and hollow metal doors without reinforcement unless door manufacturer has an alternate mounting method. Fire doors with steel reinforcement, mount devices with machine screws.

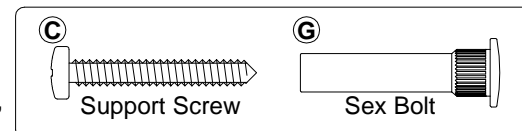

# 8 INSTALL MOUNTING BRACKET AND END CAP.

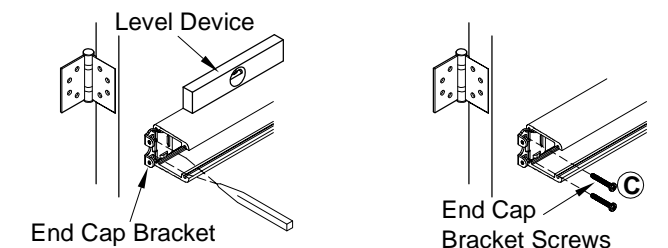

1. Remove cover plate, insert end cap bracket into push bar assembly against mechanism case. Level device, mark and drill two(2) holes for #10 sheet metal screws or #10-24 machine screws. Fasten end cap bracket screws to door.

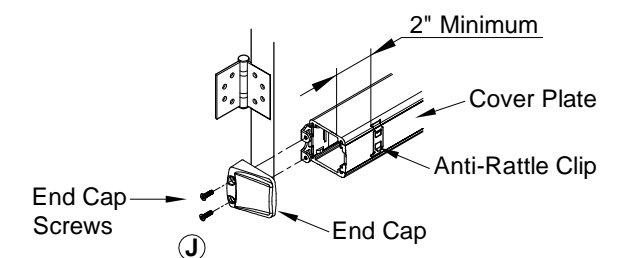

2. Insert cover plate, slide anti-rattle clip in position (2" minimum from end), and attach end cap with two(2) end cap screws.