

Exit Devices

1000 Series, 1052 Installation Instructions

Preparation

1. Determine hand of door and prepare inside of lock and hinge stiles as shown.
2. If Cylinder Key Lock is to be used, prepare inside and outside of lock stile as shown.
3. Insert Rod and Case Assembly into lock stile and secure with (2) ¼-20 Shoulder Studs
4. If Key Lock is used, insert Cylinder in Mounting Pad and secure with Locking Ring. Install using (2) #8-32x1¹⁵/₁₆" Flat Head Machine Screws.
5. Position Exit Pad over stile and attach Actuator Link to Actuator Pin using Connecting Pin provided. Place on stile over ¼-20 Shoulder Studs and tighten 3 Socket Head Set Screws to secure in place.
6. Adjust length of top and bottom Latch Bolts by turning in or out. When the Panic Arm is fully depressed, the Latch Bolts should be slightly recessed from flush with the top and bottom of the door. NOTE: Flat notch side of Bolt must face the outside of the door. Install top and bottom Latch Bolt Guides using (6) #10x½" Flat Head Self-threading Screws.
7. Install (2) ¼-20 Shoulder Studs on hinge stile. Place other Exit Pad over Studs and tighten 3 Socket Head Set Screws to secure in place.
8. Measure distance from inside edge to inside edge of Exit Pads for proper Cross Bar length. Cut Cross Bar. CAUTION: Cross Bar length must be within ± ½" for unit to function properly.
9. Loosen 3 Set Screws on hinge stile Exit Pad and install Cross Bar using (2) ¼-20x1" Oval Head Self-threading Screws. Tighten 3 Set Screws to secure in place.
10. Prepare header and threshold as shown. If Header and Threshold Strikes are required, install using (4) #8x¾" Flat Head Self-threading Screws or (4) #8x1" Flat Head All Purpose Screws.

DOGGING EXIT DEVICE USING DOGGING PIN: Fully depress Cross Bar and hold, push up Dogging Pin with screwdriver and rotate 90° in either direction. **TO RELEASE EXIT DEVICE:** Hold Cross Bar down and rotate Dogging Pin with screwdriver in either direction until Dogging Pin releases.

DOGGING EXIT DEVICE USING CYLINDER KEY: Fully depress Cross Bar and hold turn Key clockwise approximately 60°, return Key to center and remove. **TO RELEASE EXIT DEVICE:** Turn Key counterclockwise 90°, return Key to center and remove.

Exit Devices

1000 Series, 1052 Installation Instructions

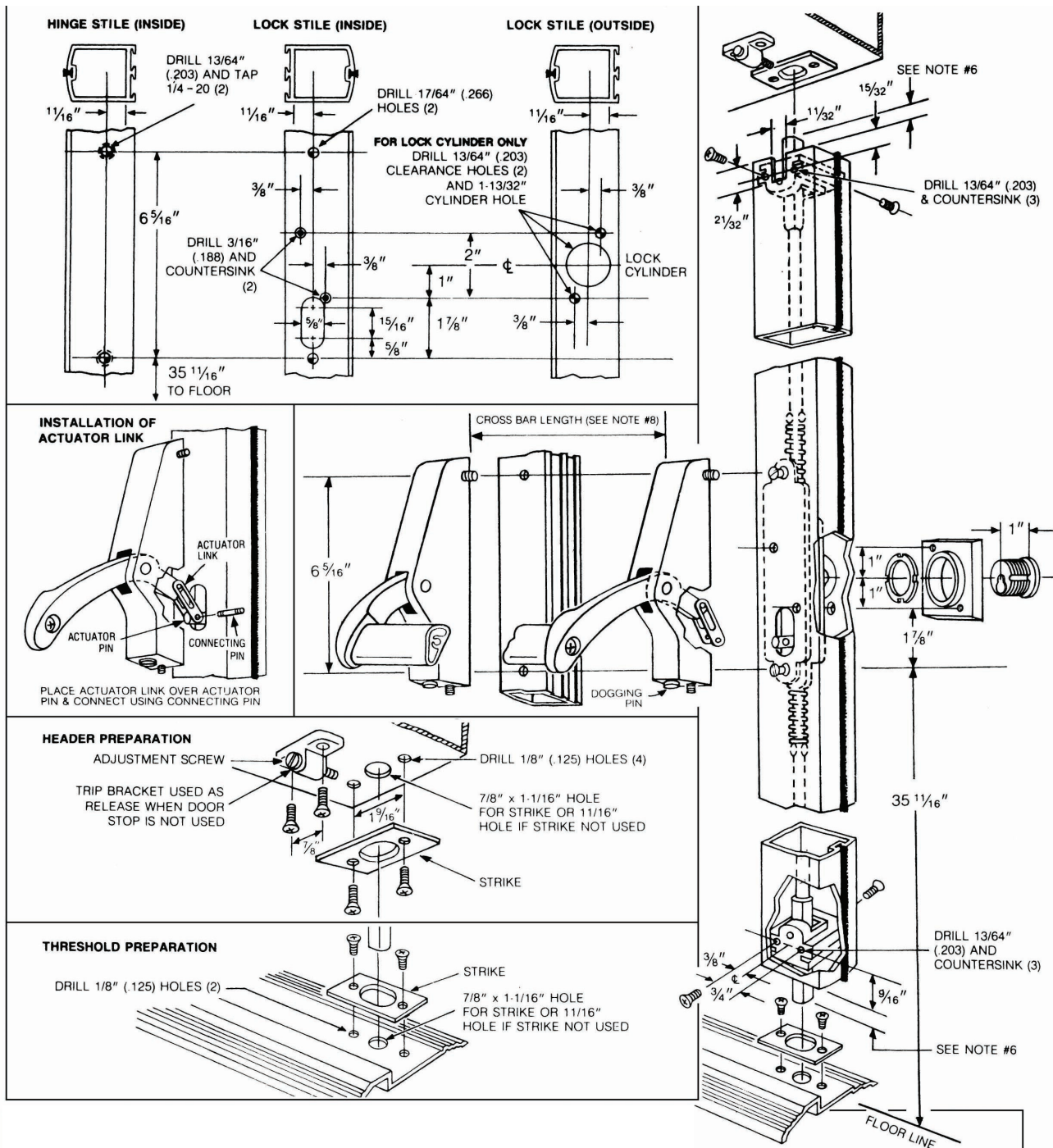

Exit Devices

1000 Series, 1052 Installation Instructions

NOTE: TEMPLATE IS NOT TO SCALE

HINGE STILE INSIDE FACE

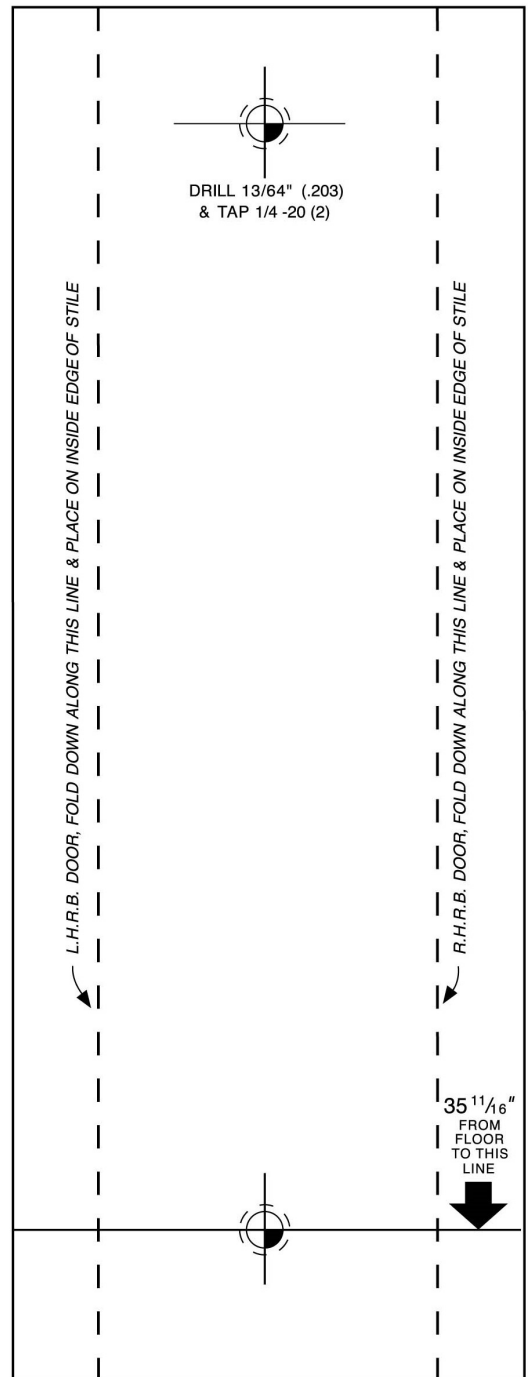

Exit Devices

1000 Series, 1052 Installation Instructions

NOTE: TEMPLATE IS NOT TO SCALE

LOCK STILE OUTSIDE FACE

