

TEMPLATE

Cylinder Pull Plate

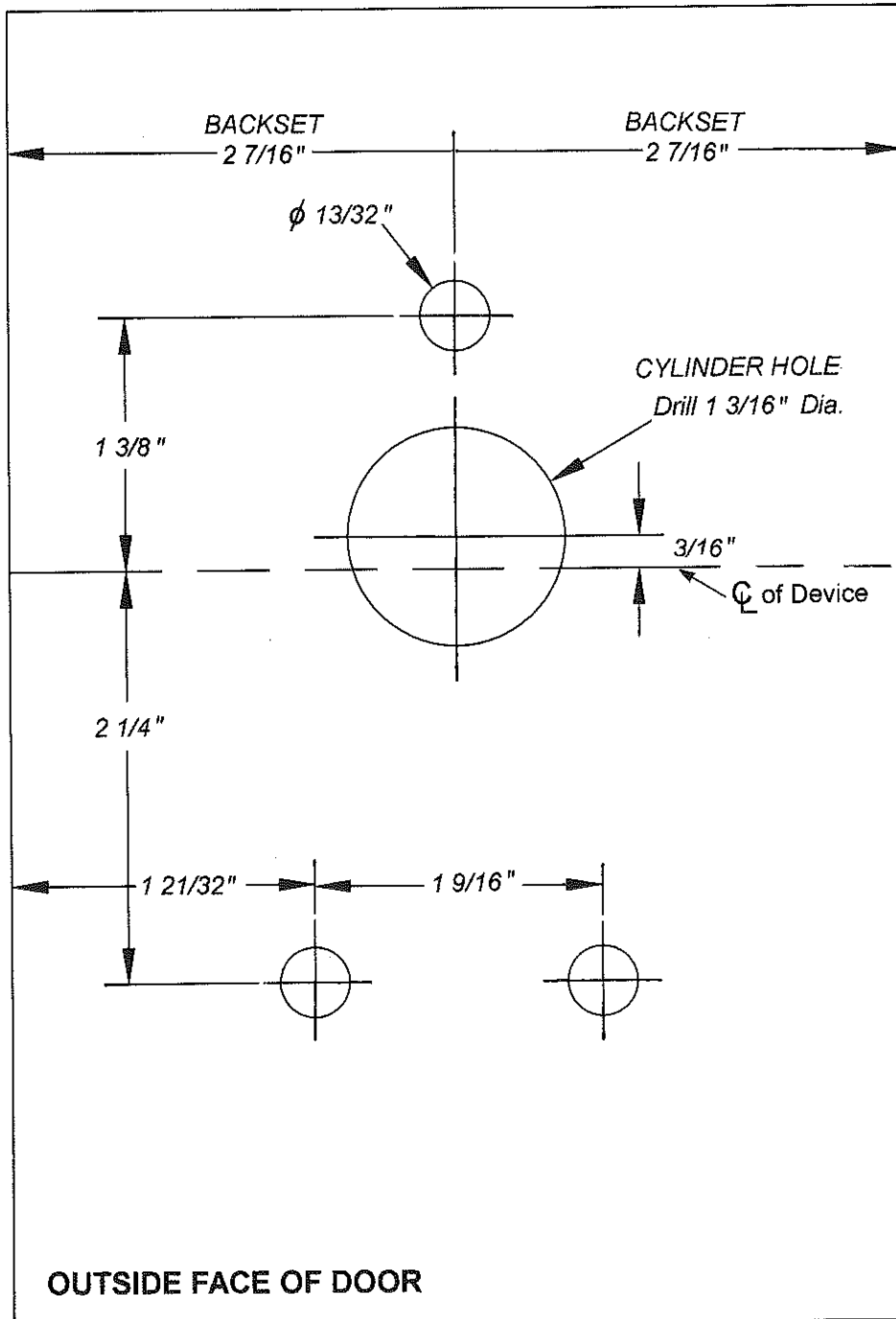

Simple Installation :

1. Drill three thru holes on outside face of door for Sex Bolts use shown as the marks :

For Metal Door Application :
9/32" Dia. Drill Inside
13/32" Dia. Drill Outside

For Wood Door Application :
13/32" Dia. Drill Thru

2. Drill 1 3/16" Dia. on outside face of door for Rim Cylinder use.

3. Screw the supplied mounting screws into the sex bolts from inside of the door. The three screws must go through the chassis of exit device.

4. Install cylinder, see Installation Instructions of Rim Exit Device.

Note :

1. For single door and double door with mullion use, the backset 2 7/16" is to *face of stop*.
2. For double door without mullion use, the backset 2 7/16" is to *edge of door*.