

# PD9100 SERIES ESCUTCHEON TRIM FOR EXIT DEVICE (PDT12 & PDT13)

## INSTALLATION INSTRUCTIONS

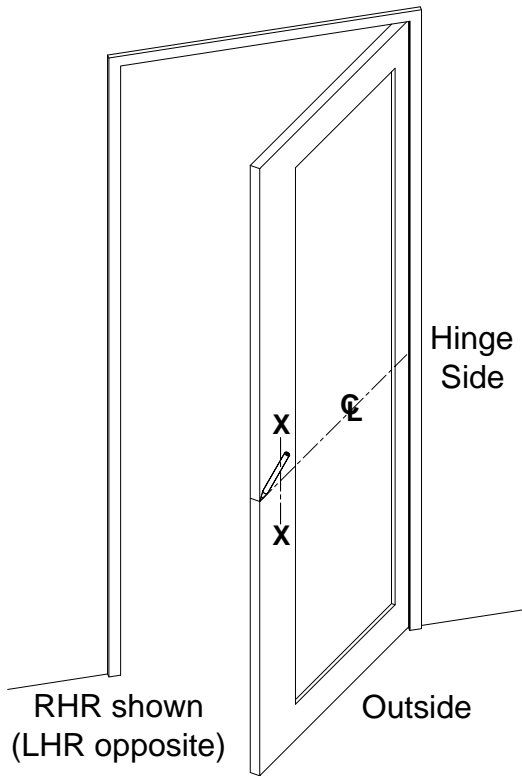

1. Prepare door for exit device. See exit device instructions for holes, backset (line X-X), and center lines.
2. Transfer line X-X from inner side (exit device) of door to outer side (trim side) of door. Use extra care if edge of door is beveled. Be sure line X-X is parallel to edge of door.

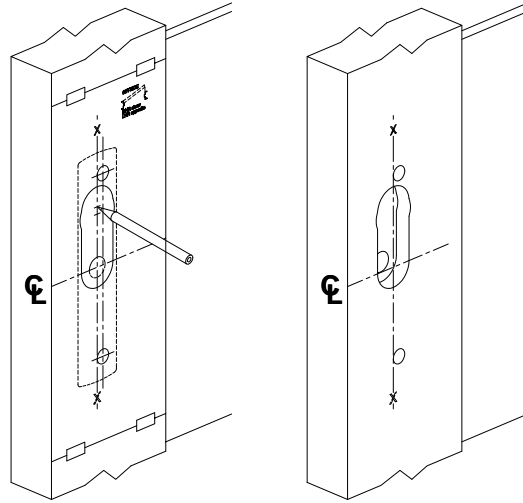

3. Locate X-X line and prepare required holes with Template.

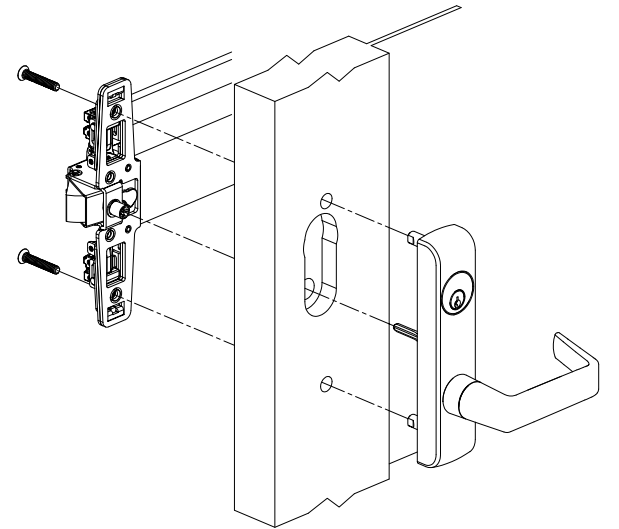

4. Determine trim handing and assemble trim. (see "HOW TO ASSEMBLE TRIM")

## HOW TO ASSEMBLE TRIM

### FOR MORTISE CYLINDER

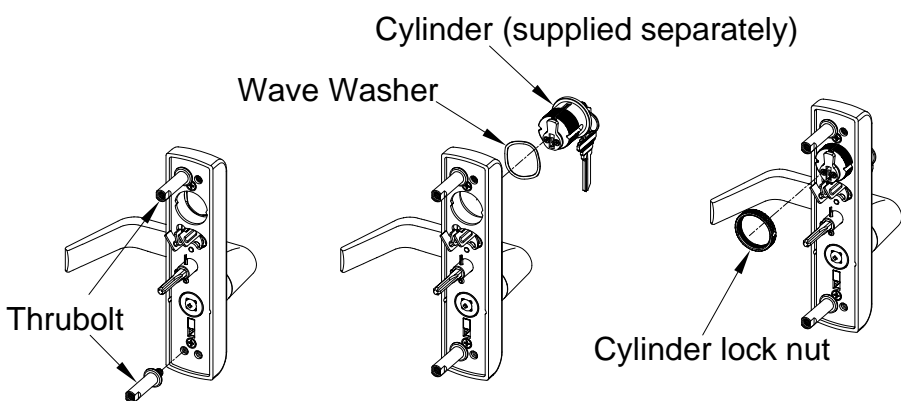

1. Use the wrench provided to fasten the thrubolt.
2. Install cylinder, wave washer into hole in escutcheon.
3. Thread cylinder lock nut onto mortise cylinder. Make sure to fasten down tight.

### FOR RIM CYLINDER

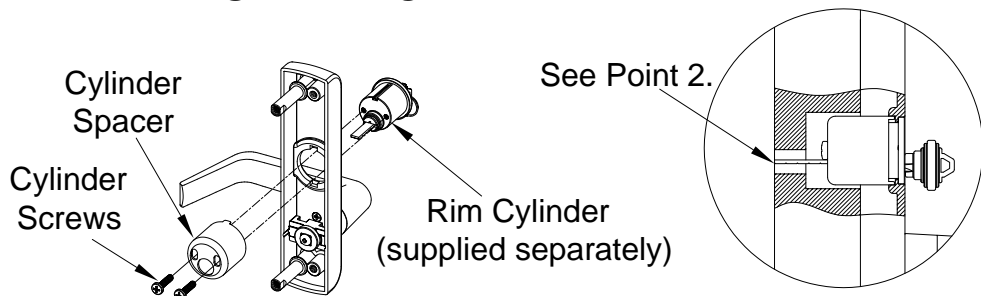

1. Mount rim cylinder to cylinder spacer and attach to outside trim with two(2) cylinder screws.
  2. Make sure the tailpiece is aligned with the inside face of door.
- NOTE:** Cut off tailpiece for different door ranges and cylinder lengths.

### FOR FUNCTIONAL LEVER

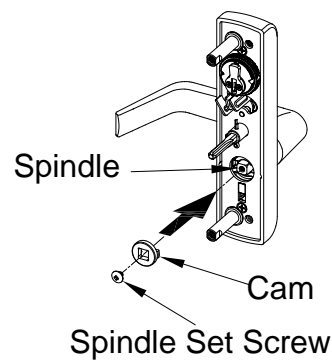

1. Determine lever handing. (RHR shown; LHR opposite)
2. Insert cam on spindle.
3. Rotate lever to check function, tighten spindle set screw.

Trim No.	PDT13	PDT12
ANSI No.	08	09
Illustration		
Cylinder Type	Mortise	Rim
Application Template	A	B

Application Template : "A" for Trim No. PDT13  
"B" for Trim No. PDT12